

MetaCentrum & CERIT-SC hands-on seminar

Tomáš Rebok

MetaCentrum, CESNET z.s.p.o.

CERIT-SC, Masaryk University

(rebok@ics.muni.cz)

Overview

- **Brief MetaCentrum introduction**
- Brief CERIT-SC Centre introduction

- Grid infrastructure overview
- How to ... specify requested resources
- How to ... run an interactive job
- How to ... use application modules
- How to ... run a batch job
- How to ... determine a job state
- How to ... run a parallel/distributed computation
- Another mini-HowTos ...
- What to do if something goes wrong?

- CERIT-SC specifics

- Real-world examples

MetaCentrum @ CESNET

- CESNET department
- since 1996, responsible for coordinating and managing **grid activities in the Czech Republic** on behalf of the **Czech NGI**
 - comprises of **clusters, powerful servers** and **storages** provided by CESNET itself as well as cooperating institutions/universities
 - → an environment for collaboration in the area of computations and data processing/management
 - interconnected with European Grid Infrastructure (EGI)



MetaCentrum NGI

- NGI coordinator
- users are grouped into **virtual organizations (VOs)**
 - a group of users having “something in common”
 - e.g., cooperating on the same project
 - may have specific HW resources assigned, specific policies set, specific technologies in use, etc.

<http://www.metacentrum.cz>

- **MetaCentrum NGI** may help with:
 - *establishment of a new HW centre*
 - *establishment of a new VO*
 - *integrating existing resources into grid infrastructure*
 - *joining a project with european infrastructures*

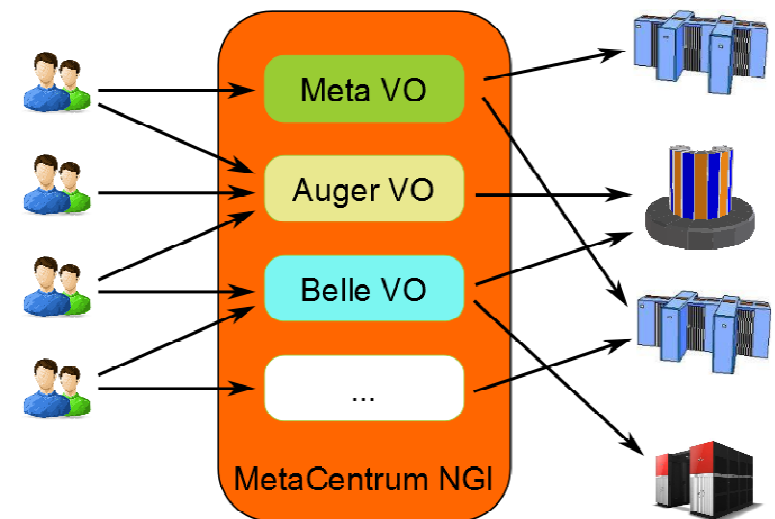

MetaCentrum VO (Meta VO)

- intended for students/employees of Czech universities, Academy of Sciences, various research institutes, etc.
- offers: <http://metavo.metacentrum.cz>
 - computing resources
 - storage capacities
 - application programs
- **free of charge (after registration)**
 - „payment“ in the form of publications with acknowledgement
 - → user priorities when the resources become fully utilized
- a part of CESNET's e-infrastructure
 - data storage/repository, collaborative environment, ...



Meta VO – hardware

- resources of CESNET + involved organizations/institutions
 - ZČU, UK, MU, CERIT-SC, FZÚ AV ČR, JČU, MZLU, VUTBR, ...
 - → CESNET performs the coordination
 - computing resources: ca **6200 cores** (x86_64)
 - common HD nodes (2x4-8 cores) as well as SMP nodes (32-80 cores)
 - memory up to 512 GB per node
 - Infiniband for low-latency communication (MPI apps)
 - **400 TB** for semi-permanent data
 - storage sites in Brno (3x) and Pilsen (1x), accessible from all clusters
 - prospectively being connected to CESNET's **PB** storage
 - availability of specialized equipment
 - e.g. NVIDIA CUDA cards in Pilsen, 35TB scratch for temporary data (Brno)
-

Meta VO – hardware

- resources of CESNET + involved organizations/institutions

What has changed in the last 6 months?

- **new clusters** – the number of cores has been increased by ca **2100**
- **installation of new clusters at JCU** in progress (further cores)
- we're finishing the purchase of **1 TB RAM machine**
- the **nodes equipped by GPU cards** are raising
- we're planning to purchase **2 new ~ 100 TB storage arrays** (Prague, Budejovice) for semi-permanent data
- an **establishment of a connection to Cesnet's PB data storage** in progress (currently used for backup only)
- ...

Meta VO – software

- similarly to HW, obtained in cooperation with involved organizations
- ~ **160 different applications** (see <http://meta.cesnet.cz/wiki/Kategorie:Aplikace>)
- **development tools**
 - GNU, Intel, PGI, debuggers and profiling tools (TotalView, Allinea)
- **mathematical software**
 - Matlab, Maple, gridMathematica
- **commercial/free software for chemistry**
 - Gaussian 09, Amber, Gamess, ...
- **material simulations**
 - Wien2k, Ansys Fluent, ...
- **structural biology, bioinformatics**
 - a set of freely available modules
- **we're looking for new software proposals (free/commercial)**
 - possibility to buy/co-finance

Meta VO – software

- similarly to HW, obtained in cooperation with involved organizations
- ~ **160 different applications** (see <http://meta.cesnet.cz/wiki/Kategorie:Aplikace>)

What has changed in the last 6 months?

- • **Matlab (8.0), Matlab basic licences increased by 100 (350 in total)**
- • **Matlab DCS/DCE increased by 128 (160 in total)**
- • **TotalView 8.10 and Alinea DDT 3.2 debuggers**
- • **Ansys CFD 14.0 (Fluent + CFX), Ansys HPC**
- • **Maple 16**
- • **PGI CDK 12.4**
- • **Intel CDK 12 licences increased by 2**
- • **SciLab, CMAQ, Moses, Mosaik, Gromacs, QEspresso, ...**

Meta VO – computing environment

- *batch jobs*
 - descriptive job script
 - information about job's start/termination
- *interactive jobs*
 - **text** vs. **graphical** mode
- *cloud environment*
 - pilot installation with CERIT-SC
 - basic compatibility with Amazon EC2
 - users **do not run jobs**, but the whole **virtual machines**
 - possibility to tune the image (Windows, Linux) and start it on MetaVO nodes
 - suitable for applications, which do not comply with the grid approach

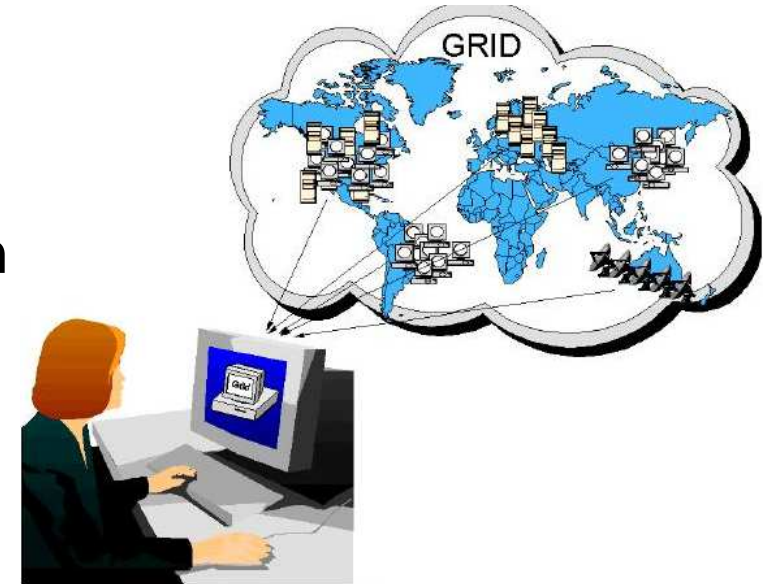



Overview

- Brief MetaCentrum introduction
- **Brief CERIT-SC Centre introduction**

- Grid infrastructure overview
- How to ... specify requested resources
- How to ... run an interactive job
- How to ... use application modules
- How to ... run a batch job
- How to ... determine a job state
- How to ... run a parallel/distributed computation
- Another mini-HowTos ...
- What to do if something goes wrong?

- CERIT-SC specifics

- Real-world examples



CERIT-SC Centre

- an important member/partner of the Czech national grid (\in MetaVO)
 - I. provider of **HW resources**
 - SMP nodes (1600 cores, already installed)
 - HD nodes (580 cores, goal Q1/2013 >2500 cores)
 - storage capacity (~3,2 PB, goal Q1/2013 >3,5 PB)

II. services beyond the scope of
a “common” HW centre –
**an environment for
collaborative research**

<http://www.cerit-sc.cz>





CERIT-SC – main activities

- Infrastructure
 - interactive, convenient for experiments (highly flexible)
 - installed technology serves primarily for research and experiments
 - the latter purpose is for common computations and data storage/processing
 - minimal paperwork (no applications)
 - Research and Development
 - **own research**, focused on principles/technologies of the maintained eInfrastructure and its optimization
 - **collaborative**, comprises of a design and optimization of algorithms, models, tools and environment based on the needs of our users/partners
 - → **a collaboration of IT experts and users**
-



Examples of collaboration with partners I.

■ Rekonstrukce stromu z jeho laserového skenu

- **partner:** *CzechGlobe* (prof. Marek, doc. Zemek, dr. Hanuš, dr. Kaplan)
- **cíl projektu:** návrh algoritmu pro rekonstrukci stromu (smrků)
 - z mraku nasnímaných 3D bodů
 - strom nasnímán laserovým snímačem LIDAR
 - výstupem jsou souřadnice XYZ + intenzita odrazu
 - *očekávaný výstup:* struktura popisující strom (Blender)
- **hlavní problémy:** překryvy (mezery v datech)

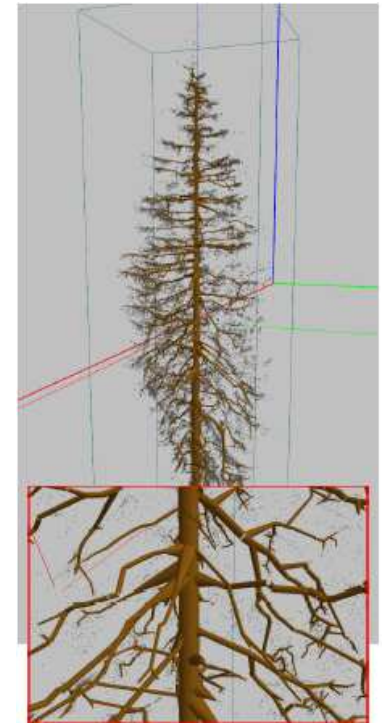



Examples of collaboration with partners II.

■ Použití neuronových sítí pro doplňování chybějících dat eddy-kovariančních měření

- **partner:** *CzechGlobe* (prof. Marek, dr. Pavelka)
- **cíl projektu:** nalezení nové, plně automatické metody pro doplňování chybějících měření
 - formou učení na historických datech
 - *doprovodné charakteristiky* – teplota, tlak, vlhkost, ...
- **hlavní problémy:**
 - nutnost brát v úvahu i historická data
 - les se vyvíjí (roste)

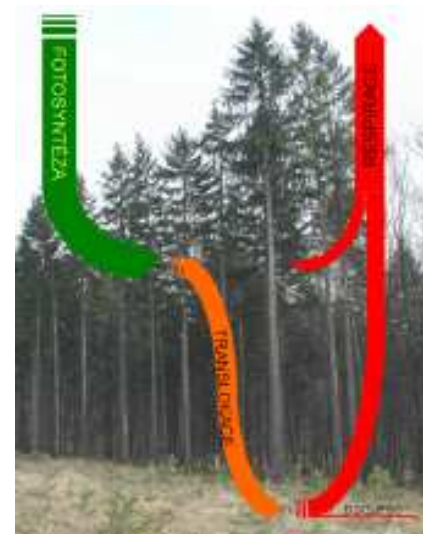



Examples of collaboration with partners II.

■ Virtuální mikroskop, patologické atlasy

- partner: *LF MU* (doc. Feit)
- cíl projektu: implementace virtuálního mikroskopu pro dermatologický atlas (webová aplikace)
 - zobrazuje skeny tkání
 - rozlišení až 170000x140000 pixelů
 - složeno z dlaždic (až 30000 ks)
 - umožňuje „doostřovat“ jako skutečný mikroskop
- hlavní problémy:
 - optimalizace zpracování snímků, autentizace

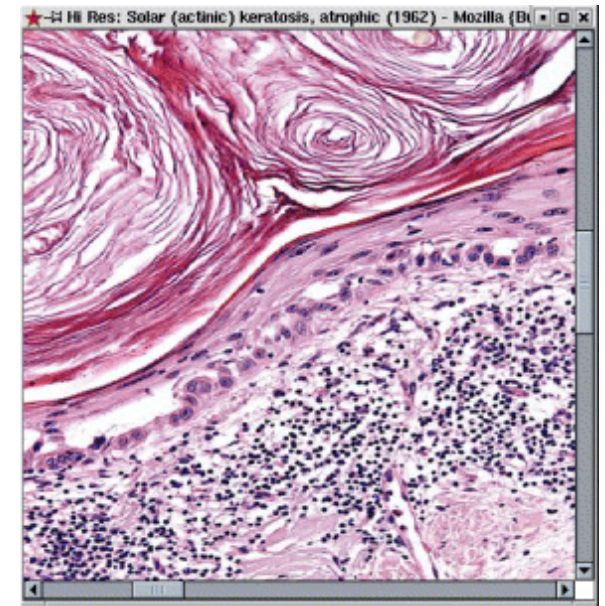



Examples of collaboration with partners IV.

- **ELIXIR (ESFRI projekt) – bio-informační infrastruktura**
 - **partner:** *ÚOCHB AV ČR* (dr. Vondrášek), *BIOMED AV ČR* (dr. Vohradský)
 - **cíl projektu:** vybudování českého uzlu evropské bio-informační infrastruktury
 - data z oblastí přírodovědy a medicíny, případně i z příslušně orientovaných průmyslových odvětví
 - potřeba s daty organizovaně zacházet
 - sdružování, správa a přístup k datům
 - nutná celoevropská a celosvětová koordinace
 - CERIT-SC je zakládající člen konsorcia ELIXIR_CZ



Examples of collaboration with partners V.

- **Biobanka klinických vzorků (BBMRI_CZ)**
 - *partner: Masarykův onkologický ústav, Recamo*
- **Modely šíření epileptického záchvatu a dalších dějů v mozku**
 - *partner: LF MU, ÚPT AV, CEITEC*
- **Fotometrický archív astronomických snímků**
- **Extrakce fotometrických údajů o objektech z astronomických snímků**
- **Automatické fitování kontinua echelletoevských spekter**
 - *3x partner: Ústav teoretické fyziky a astrofyziky PŘF MU*
- **Bioinformatická analýza dat z hmotnostního spektrometru**
 - *partner: Ústav experimentální biologie PŘF MU*
- **Identifikace oblastí zasažených geometrickými distorzemi v leteckých skenech krajiny**
- **Synchronizace časových značek v leteckých snímcích krajiny**
 - *2x partner: CzechGlobe*

...



CERIT-SC HW/SW equipment summary

Hardware:

- **SMP: 20 nodes** (*zewura* cluster)
 - **80 cores** and **512 GB** of memory per node
- **HD: 48 nodes** (*zegox* cluster)
 - **12 cores** and **90 GB** of memory per node
- the clusters' nodes interconnected by **Infiniband**
- own **storage volume** for user homes

Software:

- **exactly the same as available on the other MetaVO nodes**

Overview

- Brief MetaCentrum introduction
 - Brief CERIT-SC Centre introduction
 - **Grid infrastructure overview**
 - How to ... specify requested resources
 - How to ... run an interactive job
 - How to ... use application modules
 - How to ... run a batch job
 - How to ... determine a job state
 - How to ... run a parallel/distributed computation
 - Another mini-HowTos ...
 - What to do if something goes wrong?
 - CERIT-SC specifics
 - Real-world examples
-

Grid infrastructure overview I.

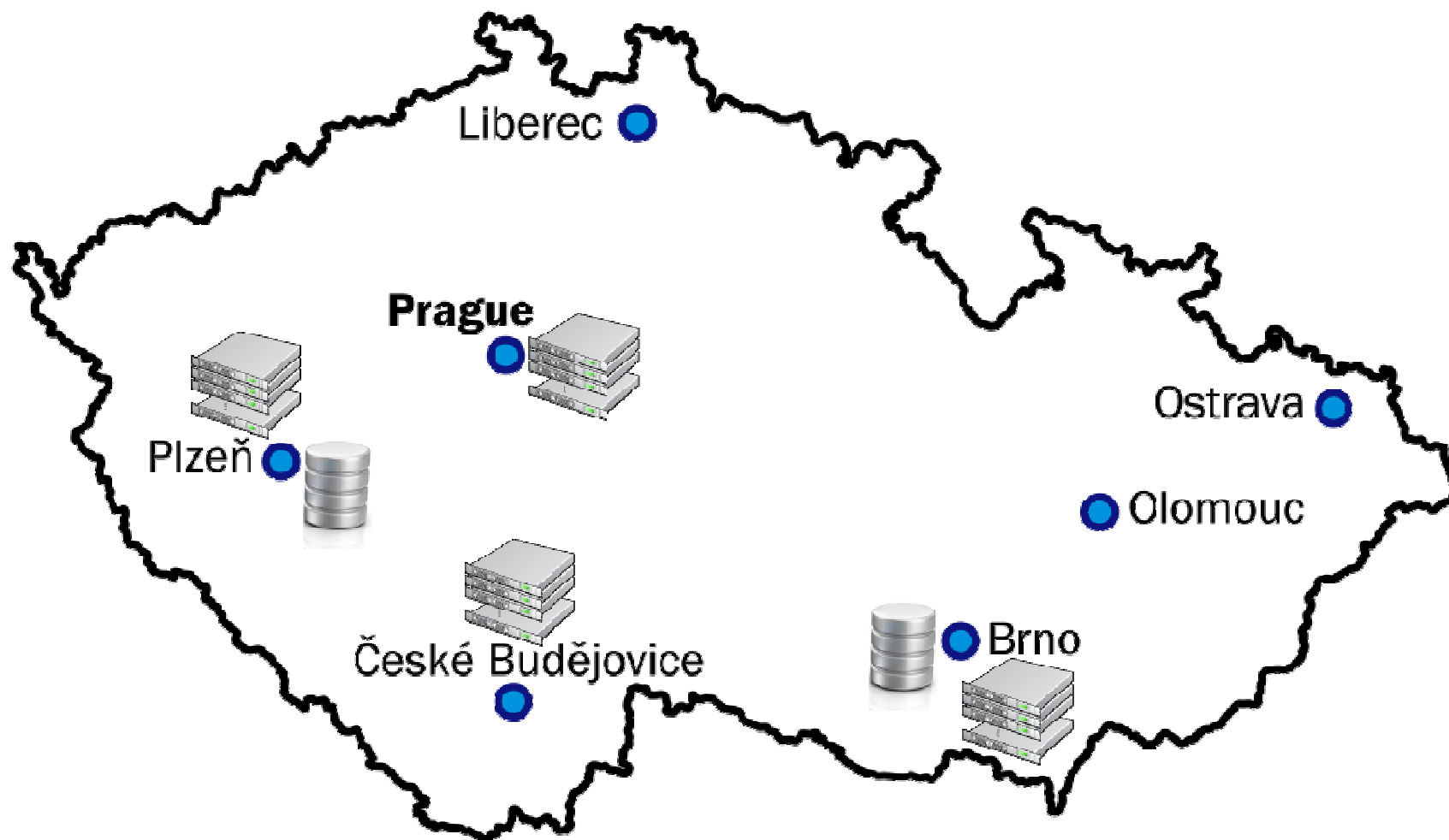

Grid infrastructure overview II.

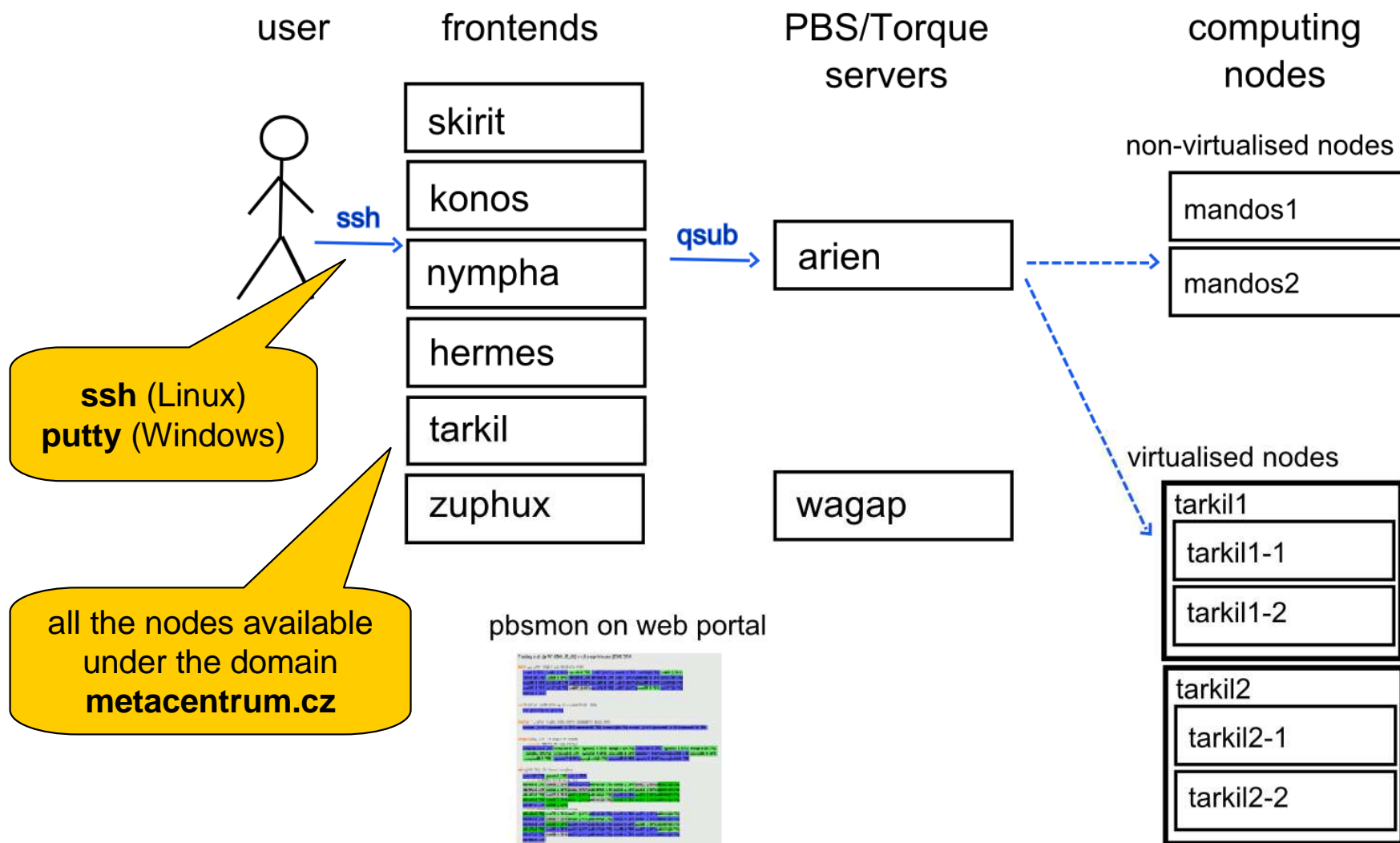

Grid infrastructure overview III.

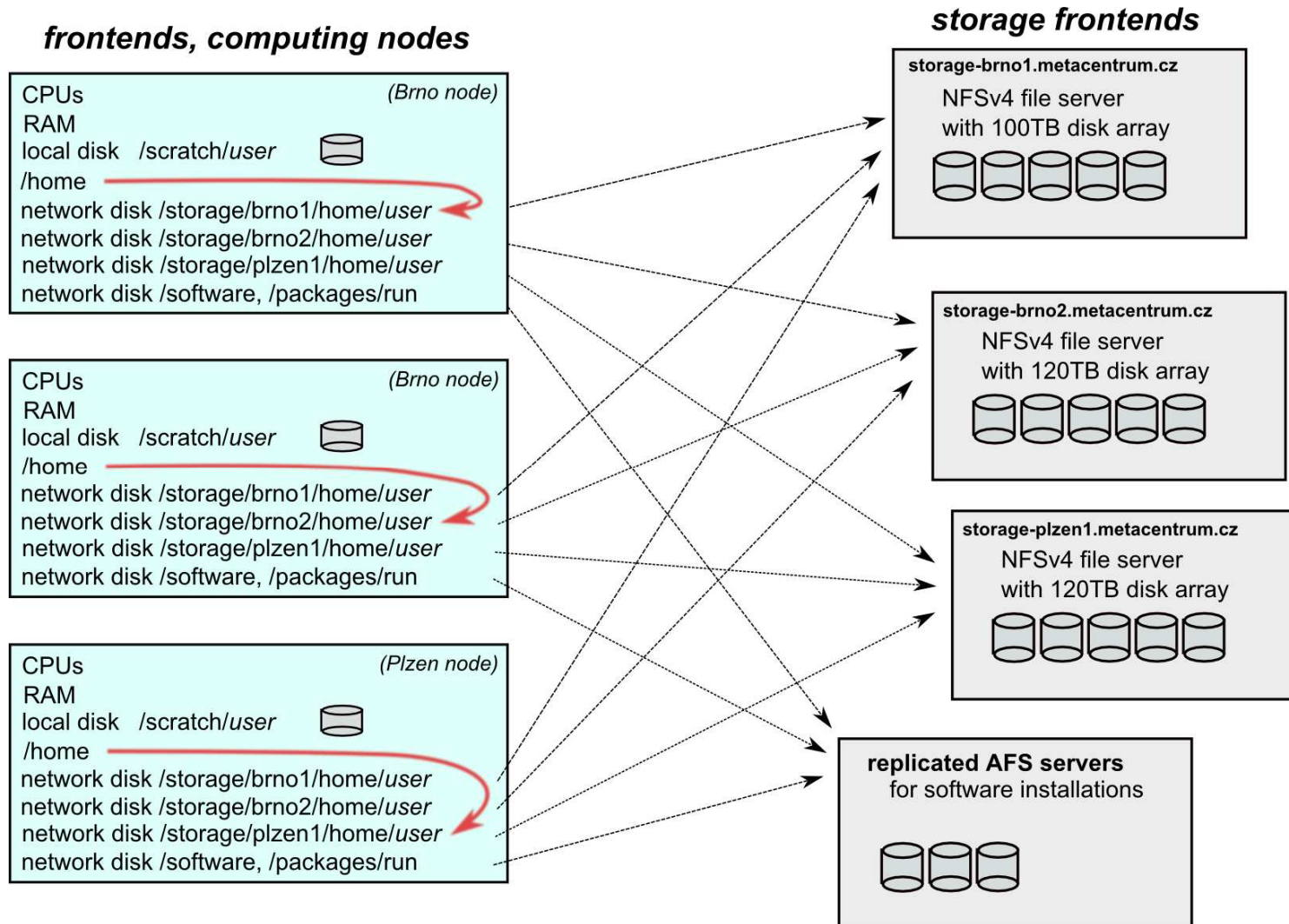

Grid infrastructure overview III.

frontends, computing nodes

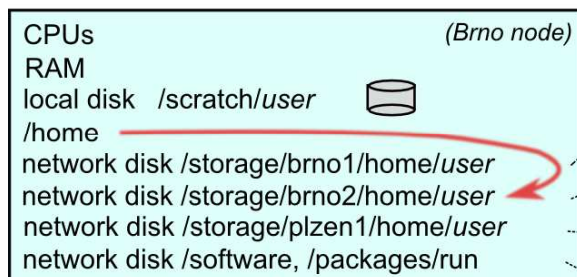
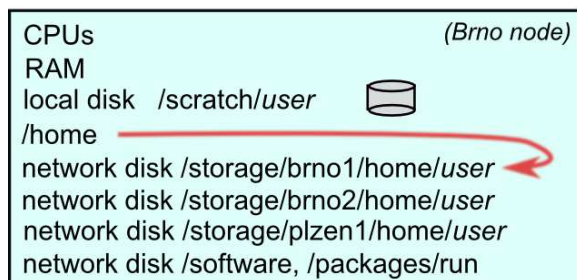

storage frontends

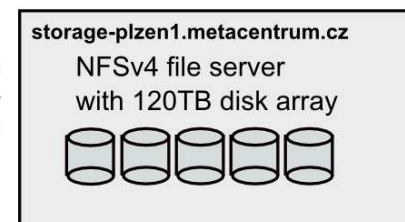
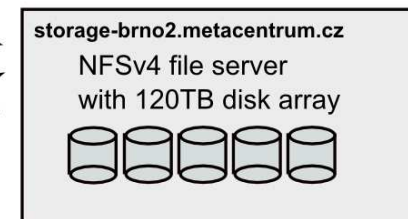
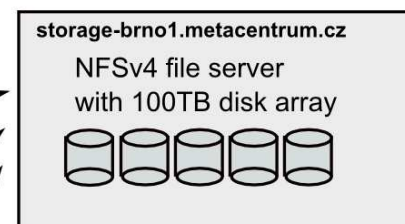

Planned improvements:

- the /storage/XXX/home/\$USER as default login directory

Overview

- Brief MetaCentrum introduction
 - Brief CERIT-SC Centre introduction

 - Grid infrastructure overview
 - **How to ... specify requested resources**
 - How to ... run an interactive job
 - How to ... use application modules
 - How to ... run a batch job
 - How to ... determine a job state
 - How to ... run a parallel/distributed computation
 - Another mini-HowTos ...
 - What to do if something goes wrong?

 - CERIT-SC specifics

 - Real-world examples
-

How to ... specify requested resources I.

- before running a job, one needs to have an idea **what resources** the job requires
 - and how many of them
- means for example:
 - number of **nodes**
 - number of **cores per node**
 - an **upper estimation** of job's **runtime**
 - amount of **free memory**
 - amount of **scratch space** for temporal data
 - number of requested **software licenses**
 - etc.
- the resource requirements are then **provided to the qsub utility** (when submitting a job)
- **details about resources' specification:**
http://meta.cesnet.cz/wiki/Plánovací_systém_-_detailní_popis#Specifikace_požadavků_na_výpočetní_zdroje

How to ... specify requested resources II.

Graphical way:

- *qsub assembler*: <http://metavo.metacentrum.cz/cs/state/personal>
- allows to:
 - graphically specify the requested resources
 - check, whether such resources are available
 - generate command line options for *qsub*
 - check the usage of MetaVO resources

Textual way:

- **more powerful** and (once being experienced user) **more convenient**
- see the following slides/examples →

How to ... specify requested resources II.

Node(s) specification:

- *general format:* `-l nodes=...`

Examples:

- 2 nodes:
 - `-l nodes=2`
- 5 nodes:
 - `-l nodes=5`
- by default, allocates just a single core on each node
 - → should be used together with **processors per node (PPN)** specification
- if “`-l nodes=...`” is not provided, just a single node with a single core is allocated

How to ... specify requested resources IV.

Processors per node (PPN) specification:

- *general format:* `-l nodes=...:ppn=...`

- 2 nodes, both of them having 3 processors:
 - `-l nodes=2:ppn=3`

- 5 nodes, each of them with 2 processors:
 - `-l nodes=5:ppn=2`

More complex specifications are also supported:

- 3 nodes: one of them with just a single processor, the other two with four processors per node:
 - `-l nodes=1:ppn=1+2:ppn=4`

- 4 nodes: one with a single processor, one with two processors, and two with four processors:
 - `-l nodes=1:ppn=1+1:ppn=2+2:ppn=4`

How to ... specify requested resources V.

Other useful nodespec features:

- nodes just from a **single (specified) cluster** (suitable e.g. for MPI jobs):
 - *general format:* `-l nodes=...:cl_<cluster_name>`
 - e.g., `-l nodes=3:ppn=1:cl_skirit`
- nodes located in a **specific location** (suitable when accessing storage in the location)
 - *general format:* `-l nodes=...:<brno|plzen|...>`
 - e.g., `-l nodes=1:ppn=4:brno`
- asking for a **specific node(s)**:
 - *general format:* `-l nodes=...:<node_name>`
 - e.g., `-l nodes=1:ppn=4:manwe3.ics.muni.cz`
- **exclusive node assignment:**
 - *general format:* `-l nodes=...#excl`
 - e.g., `-l nodes=1#excl`
- **negative specification:**
 - *general format:* `-l nodes=...:^<feature>`
 - e.g., `-l nodes=1:ppn=4:^cl_manwe`
- ...

A list of nodes' features can be found here: <http://metavo.metacentrum.cz/pbsmon2/props>

How to ... specify requested resources VI.

Specifying memory resources (default = 400mb):

- *general format:* `-l mem=...<suffix>`
 - e.g., `-l mem=300mb`
 - e.g., `-l mem=2gb`

Specifying job's maximum runtime (default = normal):

- it is necessary to assign a job into a queue, providing an upper limit on job's runtime:
 - **short** = 2 hours, **normal** (default) = 24 hours, **long** = 1 month
- *general format:* `-q <queue_name>`
 - e.g., `-q short`
 - e.g., `-q long`

How to ... specify requested resources VII.

Specifying requested scratch space:

- useful, when the application performs I/O intensive operations
 - the scratches are **local to the nodes** (smaller) and/or **shared for the nodes** of a specific cluster over Infiniband (bigger) -- currently “mandos” cluster only
 - thus being as fast as possible
- **scratch space (*amount in Kbytes*):** `-l scratch=<amount>`
 - e.g., `-l scratch=500000` (asking for 500MB)
- there is a **private scratch directory for particular job**
 - `/scratch/$USER/job_$PBS_JOBID` directory for job's scratch
- there is a **SCRATCHDIR environment variable** available in the system
 - points to the assigned scratch space/location

How to ... specify requested resources VII.

Specifying requested scratch space:

- useful when the application performs I/O intensive operations

Planned improvements:

SCRATCH:

- • possibility to set the requested scratch space in human-readable format (KB, MB, GB, ...)
- • additional property to indicate a specific scratch type requested
 - -l scratch_type=[local|shared|ssd|first]
- • reservations/quotas

General:

- a possibility to choose the nodes/cores with a particular (specified) performance (or higher)

How to ... specify requested resources VIII.

Specifying requested software licenses:

- necessary when an application requires a SW licence
 - the job becomes started once the requested licences are available
 - the information about a licence necessity is **provided within the application description** (see later)
- *general format*: `-l <lic_name>=<amount>`
 - e.g., `-l matlab=2`
 - e.g., `-l gridmath8=20`

...

(advanced) Dependencies on another jobs

- allows to create a workflow
 - e.g., to start a job once another one successfully finishes, breaks, etc.
- see `qsub`'s “`-w`” option (`man qsub`)

How to ... specify requested resources IX.

Questions and Answers:

- *Why is it necessary to specify the resources in a proper number/amount?*
 - because when a job consumes more resources than announced, it will be **killed** by us (you'll be informed)
 - otherwise it may influence other processes running on the node
- *Why is it necessary not to ask for excessive number/amount of resources?*
 - the jobs having smaller resource requirements are started (i.e., get the time slot) **faster**
- *Any other questions?*



How to ... specify requested resources X.

Examples:

- *Ask for a single node with 4 CPUs, 1gb of memory.*
 - `qsub -l nodes=1:ppn=4 -l mem=1gb`
- *Ask for a single node (1 CPU) – the job will run approx. 3 days and will consume up to 10gb of memory.*
 - `???`
- *Ask for 2 nodes (1 CPU per node) not being located in Brno.*
 - `???`
- *Ask for two nodes – a single one with 1 CPU, the other two having 5 CPUs and being from the manwe cluster.*
 - `???`
- ...



Overview

- Brief MetaCentrum introduction
 - Brief CERIT-SC Centre introduction

 - Grid infrastructure overview
 - How to ... specify requested resources
 - **How to ... run an interactive job**
 - How to ... use application modules
 - How to ... run a batch job
 - How to ... determine a job state
 - How to ... run a parallel/distributed computation
 - Another mini-HowTos ...
 - What to do if something goes wrong?

 - CERIT-SC specifics

 - Real-world examples
-

How to ... run an interactive job I.

Interactive jobs:

- result in getting a prompt on a single (**master**) node
 - one may perform interactive computations
 - the other nodes, if requested, remain allocated and accessible (see later)

- How to **ask for an interactive job**?
 - add the option “-I” to the qsub command
 - e.g., `qsub -I -l nodes=1:ppn=4:cl_mandos`

- **Example** (valid for this demo session):
 - `qsub -I -q MetaSeminar -l nodes=1`

How to ... run an interactive job II.

Textual mode: simple

Graphical mode:

- *(easier, preferred)* **tunnelling a display through ssh** (Windows/Linux):
 - connect to the frontend node having SSH forwarding/tunneling enabled:
 - Linux: `ssh -X skirit.metacentrum.cz`
 - Windows:
 - install an XServer (e.g., Xming)
 - set Putty appropriately to enable X11 forwarding when connecting to the frontend node
 - Connection → SSH → X11 → Enable X11 forwarding
 - ask for an interactive job, **adding “-x” option** to the qsub command
 - e.g., `qsub -I -x -l nodes=... ..`
- **exporting a display** from the master node to a Linux box:
 - `export DISPLAY=mycomputer.mydomain.cz:0.0`
 - on a Linux box, run “`xhost +`” to allow all the remote clients to connect
 - be sure that your display manager allows remote connections

How to ... run an interactive job III.

Questions and Answers:

- *How to **get an information** about the **other nodes allocated** (if requested)?*
 - ❑ `master_node$ cat $PBS_NODEFILE`
 - ❑ works for batch jobs as well
- *How to **use the other nodes allocated**? (holds for batch jobs as well)*
 - ❑ MPI jobs use them automatically
 - ❑ otherwise, use the **pbsdsh** utility (see "`man pbsdsh`" for details) to run a remote command
 - ❑ if the `pbsdsh` does not work for you, use the **ssh** to run the remote command
- *Any other questions?*



How to ... run an interactive job III.

Questions and Answers:

- How to **get an information** about the **other nodes allocated** (if

Hint:

- there are several useful environment variables one may use
 - `$ set | egrep "PBS|TORQUE"`
- e.g.:
 - PBS_JOBID ... job's identifier
 - PBS_NUM_NODES, PBS_NUM_PPN ... allocated number of nodes/processors
 - PBS_O_WORKDIR ... submit directory (alert: /home path!)
 - ...

)
un a



Overview

- Brief MetaCentrum introduction
 - Brief CERIT-SC Centre introduction

 - Grid infrastructure overview
 - How to ... specify requested resources
 - How to ... run an interactive job
 - **How to ... use application modules**
 - How to ... run a batch job
 - How to ... determine a job state
 - How to ... run a parallel/distributed computation
 - Another mini-HowTos ...
 - What to do if something goes wrong?

 - CERIT-SC specifics

 - Real-world examples
-

How to ... use application modules I.

Application modules:

- the **modullar subsystem** provides a user interface to modifications of user environment, which are necessary for running the requested applications
- allows to “add” an application to a user environment

- **getting a list** of available application modules:
 - `$ module avail`
 - <http://meta.cesnet.cz/wiki/Kategorie:Aplikace>
 - provides the documentation about modules' usage
 - besides others, includes:
 - information whether it is necessary to ask the scheduler for an available licence
 - information whether it is necessary to express consent with their licence agreement

How to ... use application modules II.

Application modules:

- **loading** an application into the environment:
 - `$ module add <modulename>`
 - e.g., `module add maple`
 - **listing** the already loaded modules:
 - `$ module list`
 - **unloading** an application from the environment:
 - `$ module del <modulename>`
 - e.g., `module del openmpi`
 - **Note:** *An application may require to express consent with its licence agreement before it may be used (see the application's description). To provide the agreement, visit the following webpage: <http://metavo.metacentrum.cz/cs/myaccount/eula>*
 - for more information about application modules, see http://meta.cesnet.cz/wiki/Aplikační_moduly
-

Overview

- Brief MetaCentrum introduction
 - Brief CERIT-SC Centre introduction

 - Grid infrastructure overview
 - How to ... specify requested resources
 - How to ... run an interactive job
 - How to ... use application modules
 - **How to ... run a batch job**
 - How to ... determine a job state
 - How to ... run a parallel/distributed computation
 - Another mini-HowTos ...
 - What to do if something goes wrong?

 - CERIT-SC specifics

 - Real-world examples
-

How to ... run a batch job I.

Batch jobs:

- perform the computation as described in their **startup script**
 - the submission results in getting a **job identifier**, which further serves for getting more information about the job (see later)

- How to **submit a batch job**?
 - add the reference to the startup script to the qsub command
 - e.g., `qsub -l nodes=3:ppn=4:cl_mandos <myscript.sh>`

- **Example** (valid for this demo session):
 - `qsub -q MetaSeminar -l nodes=1 myscript.sh`
 - results in getting something like `"12345.arien.ics.muni.cz"`

How to run a batch job I

Hint:

B

- create the file `myscript.sh` with the following content:

- ```
$ vim myscript.sh
```

```
#!/bin/bash
```

```
my first batch job
```

```
uname -a
```

- see the standard output file (`myscript.sh.o<JOBID>`)

- ```
$ cat myscript.sh.o<JOBID>
```

■ **Example** (valid for this demo session):

❑ `qsub -q MetaSeminar -l nodes=1 myscript.sh`

❑ results in getting something like `"12345.arien.ics.muni.cz"`

for

How to ... run a batch job II.

Startup script preparation/skelet: (non IO-intensive computations)

```
#!/bin/bash
```

```
DATADIR="/storage/brno1/home/$USER/" # shared via NFSv4
```

```
cd $DATADIR
```

```
# ... initialize & load modules, perform the computation ...
```

- **further details** – see http://meta.cesnet.cz/wiki/Plánovací_systém_-_detailní_popis#Příklady_použití

How to ... run a batch job III.

Startup script preparation/skelet: (IO-intensive computations or long-term jobs)

```
#!/bin/bash

DATADIR="/storage/brnol/home/$USER/"

# prepare the input data
cp $DATADIR/input.txt $SCRATCHDIR || exit 1

# go to the working directory and perform the computation
cd $SCRATCHDIR

# ... initialize & load modules, perform the computation ...

# move out the output data
cp $SCRATCHDIR/output.txt $DATADIR

if [ $? -ne 0 ]; then
    echo "Copy output data failed. Copy them manually from `hostname`" 1>&2
    exit 2
fi

# clean the scratch temporal directory
rm -rf $SCRATCHDIR
```

How to ... run a batch job IV.

Using the application modules within the batch script:

- to use the **application modules** from a **batch script**, add the following line into the script (before loading the module):

```
. /packages/run/modules-2.0/init/sh
```

```
...
```

```
module add maple
```

Getting the job's standard output and standard error output:

- once finished, there appear **two files** in the directory, which the job has been started from:
 - ❑ `<job_name>.o<jobID>` ... standard output
 - ❑ `<job_name>.e<jobID>` ... standard error output
- ❑ the `<job_name>` can be modified via the `"-N"` qsub option

How to ... run a batch job V.

Job attributes specification:

in the case of batch jobs, the requested resources and further job information (*job attributes* in short) may be specified either on the command line (see "man qsub") or directly within the script:

- by adding the "#PBS" directives (see "man qsub"):

```
#PBS -N Job_name
#PBS -l nodes=2:ppn=1
#PBS -l mem=320kb
#PBS -m abe
#
< ... commands ... >
```

- the submission may be then simply performed by:

```
□ $ qsub myscript.sh
```

How to ... run a batch job V.

Questions and Answers:

- *Should I prefer batch or interactive jobs?*
 - definitely the **batch ones** – they use the computing resources **more effectively**
 - use the interactive ones just for testing your startup script, GUI apps, or data preparation

- *Any other questions?*



How to ... run a batch job VI.

Example:

- Create and submit a batch script, which performs a simple Maple computation, described in a file:

```
plotsetup(gif,  
          plotoutput=`/storage/brno1/home/<username>/myplot.gif`,  
          plotoptions=`height=1024,width=768`);  
plot3d( x*y, x=-1..1, y=-1..1, axes = BOXED, style =  
        PATCH);
```

- process the file using Maple (from a batch script):
 - hint: \$ maple <filename>

How to ... run a batch job VI.

Example:

- Create and submit a batch script, which performs a simple Maple computation, described in a file:

```
plotsetup(gif,  
  plotoutput=`/storage/brno1/home/<username>/myplot.gif`,  
  plotoptions=`height=1024,width=768`);  
plot3d( x*y, x=-1..1, y=-1..1, axes = BOXED, style =  
  PATCH);
```

- process the file using Maple (from a batch script):
 - hint: \$ maple <filename>

Hint:

- see the solution at
</storage/brno2/home/jeronimo/MetaSeminar/20121213-IBA/maple>

Overview

- Brief MetaCentrum introduction
 - Brief CERIT-SC Centre introduction

 - Grid infrastructure overview
 - How to ... specify requested resources
 - How to ... run an interactive job
 - How to ... use application modules
 - How to ... run a batch job
 - **How to ... determine a job state**
 - How to ... run a parallel/distributed computation
 - Another mini-HowTos ...
 - What to do if something goes wrong?

 - CERIT-SC specifics

 - Real-world examples
-

How to ... determine a job state I.

Job identifiers

- every job (no matter whether interactive or batch) is **uniquely identified** by its identifier (JOBID)
 - e.g., `12345.arien.ics.muni.cz`
- to obtain any information about a job, the **knowledge of its identifier is necessary**
 - how to list all the recent jobs?
 - graphical way – PBSMON: <http://metavo.metacentrum.cz/pbsmon2/jobs/allJobs>
 - `frontend$ qstat` (run on any frontend)
 - how to list all the recent jobs of a specific user?
 - graphical way – PBSMON: <http://metavo.metacentrum.cz/pbsmon2/jobs/my>
 - `frontend$ qstat -u <username>` (again, any frontend)

How to ... determine a job state II.

How to determine a job state?

- graphical way – see PBSMON
 - list all your jobs and click on the particular job's identifier
 - <http://metavo.metacentrum.cz/pbsmon2/jobs/my>
- textual way – `qstat` command (see `man qstat`)
 - brief information about a job: `$ qstat JOBID`
 - informs about: job's state (*Q=queued*, *R=running*, *E=exiting*, *C=completed*, ...), job's runtime, ...
 - complex information about a job: `$ qstat -f JOBID`
 - shows all the available information about a job
 - useful properties:
 - *exec_host* -- the nodes, where the job did really run
 - *resources_used*, *start/completion time*, *exit status*, ...

How to ... determine a job state III.

Hell, when my jobs will really start?

- nobody can tell you ☺
 - the **God/scheduler decides** (based on the other job's finish)
 - we're working on an estimation method to inform you about its probable startup

- check the **queues' fulfilment**:
<http://metavo.metacentrum.cz/cs/state/jobsQueued>
 - the higher fairshare (queue's AND job's) is, the earlier the job will be started
- **stay informed** about job's startup / finish / abort (via email)
 - by default, just an information about job's abortion is sent
 - → when submitting a job, add “-m abe” option to the `qsub` command to be informed about all the job's states
 - or “#PBS -m abe” directive to the startup script

How to ... determine a job state IV.

Monitoring running job's stdout, stderr, working/temporal files

1. via ssh, log in directly to the execution node(s)
 - how to get the job's execution node(s)?
 - to examine the working/temporal files, navigate directly to them
 - logging to the execution node(s) is necessary -- even though the files are on a shared storage, their content propagation takes some time
 - to examine the stdout/stderr of a running job:
 - navigate to the `/var/spool/torque/spool/` directory and examine the files:
 - `$PBS_JOBID.OU` for standard output (stdout – e.g., “1234.arien.ics.muni.cz.OU”)
 - `$PBS_JOBID.ER` for standard error output (stderr – e.g., “1234.arien.ics.muni.cz.ER”)

Job's forcible termination

- `$ qdel JOBID` (the job may be terminated in any previous state)
- during termination, the job turns to *E (exiting)* and finally to *C (completed)* state

Overview

- Brief MetaCentrum introduction
 - Brief CERIT-SC Centre introduction

 - Grid infrastructure overview
 - How to ... specify requested resources
 - How to ... run an interactive job
 - How to ... use application modules
 - How to ... run a batch job
 - How to ... determine a job state
 - **How to ... run a parallel/distributed computation**
 - Another mini-HowTos ...
 - What to do if something goes wrong?

 - CERIT-SC specifics

 - Real-world examples
-

How to ... run a parallel/distributed computation I.

Parallel jobs (OpenMP):

- if your application is able to use multiple threads via a shared memory, **ask for a single node with multiple processors**

```
$ qsub -l nodes=1:ppn=...
```

- **make sure**, that before running your application, the **OMP_NUM_THREADS** environment variable **is appropriately set**

- otherwise, your application will use all the cores available on the node
 - → and influence other jobs...

- usually, setting it to **PPN** is OK

```
$ export OMP_NUM_THREADS=$PBS_NUM_PPN
```

How to ... run a parallel/distributed computation II.

Distributed jobs (MPI):

- if your application consists of multiple processes communicating via a message passing interface, **ask for a set of nodes** (with arbitrary number of processors)

```
$ qsub -l nodes=...:ppn=...
```

- **make sure**, that before running your application, the appropriate **openmpi/mpich2/lam** module is loaded into the environment

```
$ module add openmpi
```

- then, you can use the `mpirun/mpiexec` routines

```
$ mpirun myMPIapp
```

- it's **not necessary** to provide these routines neither with the number of nodes to use ("`-np`" option) nor with the nodes itself ("`--hostfile`" option)
 - the computing nodes are **automatically detected** by the `openmpi/mpich2/lam`

How to ... run a parallel/distributed computation III.

Distributed jobs (MPI): accelerating their speed I.

- to accelerate the speed of MPI computations, ask just for the nodes interconnected by a **low-latency Infiniband interconnection**
 - all the nodes of a cluster are interconnected by Infiniband
 - there are several clusters having an Infiniband interconnection
 - mandos, minos, hildor, skirit, tarkil, nympha, zewura + zegox (CERIT-SC)

- *submission example:*

```
$ qsub -l nodes=4:ppn=2:cl_mandos myMPIscript.sh
```

- *starting the MPI computation making use of an Infiniband:*
 - in a common way: `$ mpirun myMPIapp`
 - the Infiniband will be automatically detected

How to ... run a parallel/distributed computation III.

Distributed jobs (MPI): accelerating their speed I.

- to accelerate the speed of MPI computations, ask just for the nodes interconnected by a **low-latency Infiniband interconnection**
 - all the nodes of a cluster are interconnected by Infiniband
 - there are several clusters having an Infiniband interconnection
 - mandos, minos, hildor, skirit, tarkil, nympha, zewura + zegox (CERIT-SC)
- *submission example:*

```
$ qsub -l nodes=4:ppn=2:cl_mandos myMPIscript.sh
```

Planned improvements:

- an intelligent “infiniband” attribute
 - just the nodes interconnected with a shared IB switch will be chosen

How to ... run a parallel/distributed computation IV.

Distributed jobs (MPI): accelerating their speed II.

- to test the functionality of an Infiniband interconnection:
 - create a simple program `hello.c` as described here:
<http://www.slac.stanford.edu/comp/unix/farm/mpi.html>
 - compile with "mpicc"

```
$ module add openmpi  
$ mpicc hello.c -o hello
```
 - run the binary (within a job) with the following command:

```
$ mpirun --mca btl ^tcp hello
```

How to ... run a parallel/distributed computation IV.

Distributed jobs (MPI): accelerating their speed II.

- to test the functionality of an Infiniband interconnection:
 - create a simple program `hello.c` as described here:
<http://www.slac.stanford.edu/comp/unix/farm/mpi.html>
 - compile with "mpicc"

```
$ module add openmpi  
$ mpicc hello.c -o hello
```
 - run the binary (within a job) with the following command:

```
$ mpirun --mca btl ^tcp hello
```

Hint:

- see the solution at `/storage/brno2/home/jeronimo/MetaSeminar/20121213-IBA/IB_hello`

How to ... run a parallel/distributed computation V.

Questions and Answers:

- *Is it possible to simultaneously use both OpenMP and MPI?*
 - Yes, it is. But be sure, how many processors your job is using
 - appropriately set the “-np” option (MPI) and the OMP_NUM_THREADS variable (OpenMP)

- Any other questions?



Overview

- Brief MetaCentrum introduction
 - Brief CERIT-SC Centre introduction

 - Grid infrastructure overview
 - How to ... specify requested resources
 - How to ... run an interactive job
 - How to ... use application modules
 - How to ... run a batch job
 - How to ... determine a job state
 - How to ... run a parallel/distributed computation
 - **Another mini-HowTos ...**
 - What to do if something goes wrong?

 - CERIT-SC specifics

 - Real-world examples
-

Another mini-HowTos ... I.

■ how to transfer large amount of data to MetaVO nodes?

- copying through the frontends/computing nodes may not be efficient
- → connect directly to the storage frontends (via **SCP** or **SFTP**)
 - `$ sftp storage-brno1.metacentrum.cz`
 - `$ scp <files> storage-plzen1.metacentrum.cz:<dir>`
 - etc.
 - use FTP only together with the Kerberos authentication
 - otherwise insecure

■ how to access the data arrays?

- **easier:** use the SFTP/SCP protocols (suitable applications)
- **OR mount the storage arrays directly to your computer**
 - http://meta.cesnet.cz/wiki/P%C5%99ipojen%C3%AD_dato_v%C3%BDch_%C3%BAlo%C5%BEi%C5%A1%C5%A5_k_vlastn%C3%AD_pracovn%C3%AD_stanici_p%C5%99es_NFSv4

Another mini-HowTos ... II.

■ how to secure private data?

- by default, all the data are readable by everyone
- → use common Linux/Unix mechanisms/tools to make the data private
 - r, w, x rights for *user, group, other*
 - e.g., `chmod go= <filename>`
 - see `man chmod`
 - use “-R” option for recursive traversal (applicable to directories)

■ how to restore accidentally erased data

- the storage arrays (⇒ including homes) are regularly backed-up
 - several times a week
- → write an email to meta@cesnet.cz specifying what to restore

Overview

- Brief MetaCentrum introduction
 - Brief CERIT-SC Centre introduction

 - Grid infrastructure overview
 - How to ... specify requested resources
 - How to ... run an interactive job
 - How to ... use application modules
 - How to ... run a batch job
 - How to ... determine a job state
 - How to ... run a parallel/distributed computation
 - Another mini-HowTos ...
 - **What to do if something goes wrong?**

 - CERIT-SC specifics

 - Real-world examples
-

What to do if something goes wrong?

1. check the MetaVO/CERIT-SC documentation, application module documentation
 - whether you use the things correctly
2. check, whether there haven't been any infrastructure updates performed
 - visit the webpage https://meta.cesnet.cz/wiki/Provozní_změny
 - one may stay informed via an RSS feed
3. write an email to meta@cesnet.cz, resp. support@cerit-sc.cz
 - your email will create a ticket in our Request Tracking system
 - identified by a unique number → one can easily monitor the problem solving process
 - please, include **as good problem description as possible**
 - problematic job's JOBID, startup script, problem symptoms, etc.



Overview

- Brief MetaCentrum introduction
 - Brief CERIT-SC Centre introduction

 - Grid infrastructure overview
 - How to ... specify requested resources
 - How to ... run an interactive job
 - How to ... use application modules
 - How to ... run a batch job
 - How to ... determine a job state
 - How to ... run a parallel/distributed computation
 - Another mini-HowTos ...
 - What to do if something goes wrong?

 - **CERIT-SC specifics**

 - Real-world examples
-



CERIT-SC specifics

In comparison with the MetaVO infrastructure, the CERIT-SC infrastructure has several specifics:

- own **frontend** (`zuphux.cerit-sc.cz`)
- own **scheduling server** (`wagap.cerit-sc.cz`)
- **no queues** for jobs' maximum runtime specification
 - the maximum runtime is specified via a `qsub`'s `walltime` parameter



CERIT-SC: job submission

From CERIT-SC frontend (zuphux.cerit-sc.cz):

- “common way” (just the `walltime` specification is necessary – see later)

From MetaCentrum frontends:

- necessary to specify the CERIT-SC’s scheduling server:
- `skirit$ qsub -q @wagap.cerit-sc.cz -l ...`
- `skirit$ qstat -q @wagap.cerit-sc.cz`
- `skirit$ qstat -f 12345.wagap.cerit-sc.cz`
- ...

Note: *It is also possible to submit MetaVO jobs from the CERIT-SC frontend:*

- `zuphux$ qsub -q short@arlen.ics.muni.cz -l ...`
- `zuphux$ qstat -q @arlen.ics.muni.cz`
- `zuphux$ qstat -f 12345.arlen.ics.muni.cz`
- ...

- details: <http://www.cerit-sc.cz/cs/docs/access/>



CERIT-SC: maximum job's runtime specification

- **no queues**
- specified using the `qsub`'s **`walltime` parameter** (default value **24 hours**)
 - *general format:*
`-l walltime=[[hours:]minutes:]seconds[.milliseconds]`
- *examples:*
 - `$ qsub -l walltime=30 myjob.sh` - a request to submit the *myjob.sh* script, specifying its maximum run-time in the length of 30 seconds (submitted via the CERIT-SC frontend)
 - `$ qsub -l walltime=10:00 myjob.sh` - a request to submit the *myjob.sh* script, specifying its maximum run-time in the length of 10 minutes (submitted via the CERIT-SC frontend)
 - `$ qsub -q @wagap.cerit-sc.cz -l walltime=100:15:00 myjob.sh` - a request to submit the *myjob.sh* script, specifying its maximum run-time in the length of 100 hours and 15 minutes (submitted via a MetaCentrum frontend)

Overview

- Brief MetaCentrum introduction
 - Brief CERIT-SC Centre introduction

 - Grid infrastructure overview
 - How to ... specify requested resources
 - How to ... run an interactive job
 - How to ... use application modules
 - How to ... run a batch job
 - How to ... determine a job state
 - How to ... run a parallel/distributed computation
 - Another mini-HowTos ...
 - What to do if something goes wrong?

 - CERIT-SC specifics

 - **Real-world examples**
-

Real-world examples

Examples:

- Maple
- Gromacs
- Scilab
- parallel Matlab

■ **demo sources:**

`/storage/brno2/home/jeronimo/MetaSeminar/20121213-IBA`

command:

```
cp -r /storage/brno2/home/jeronimo/MetaSeminar/20121213-IBA $HOME
```

Thank You for attending!



rebok@ics.muni.cz

www.cesnet.cz

www.metacentrum.cz

www.cerit-sc.cz